

# Flexi-Vision<sup>TM</sup>

## FLOOR LAMP



Fact Sheet



This product is the result of extensive research and collaboration with the RNIB and other low vision specialists. The 15W daylight energy saving bulb reduces glare and improves contrast allowing you to read and write for longer in optimal comfort. The Flexi-Vision Floor lamp is also one of the safest lamps on the market with clear on/off switch location, anti-trip cable holders and low heat shade.

---

LED 6,000K daylight

---

---

2,560 Lux at 12"

---

---

LED bulb included

---



LIGHT QUALITY



ERGONOMICS



DESIGN

[daylightcompany.com](http://daylightcompany.com)

# Flexi-Vision™

D31067

## FLOOR LAMP

### FEATURES

- Unique floor lamp, designed in cooperation with the RNIB
- Low heat shade fitted with 15W daylight™ LED bulb (100W equiv.)
- Daylight™ technology reduces glare and improves contrast
- Read and write for longer in optimal comfort
- Height adjustable for reading on a sofa or at a table
- Flexible arm for easy positioning and extra reach
- Multi-swivel head to direct the light where you need it
- Anti-trip cable holders and clear on/off switch location
- Large wing nut for easy height adjustment
- Well-balanced base for enhanced stability

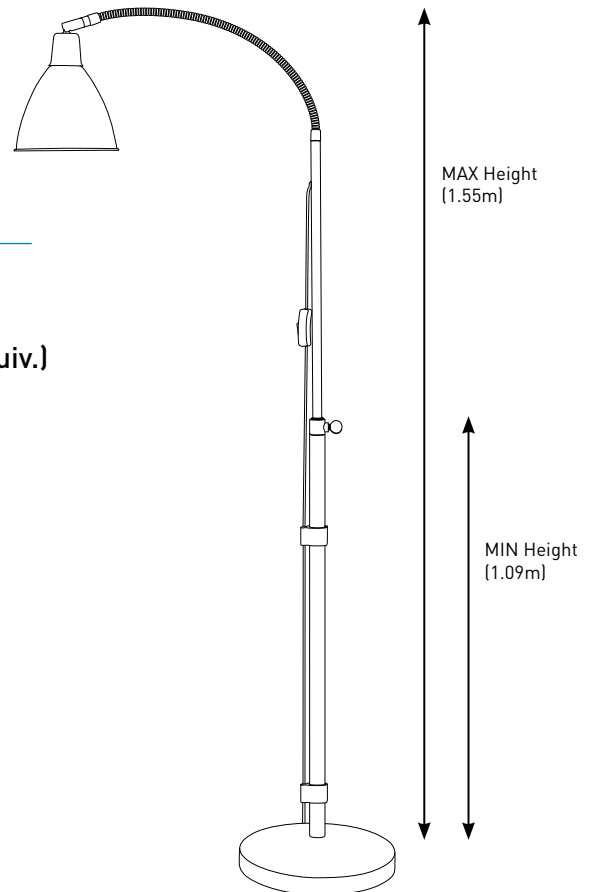

### SPECIFICATIONS

#### Product information

Weight	6kg
Colour	Brushed Steel
Cable length	2m

#### Light output

Light source	LED
Lux Levels at 30cm	2,650
Lumens	1,600
Colour temperature	6,000K
CRI	80+
Energy consumption	15W

#### Packaging information

Height	75.4cm
Width	36cm
Depth	16cm
Packed weight	7.5kg
Products per master carton	1
Barcode Number	8 09802 31067 2

# Flexi-Vision<sup>TM</sup>

## FLOOR LAMP



Fact Sheet



This product is the result of extensive research and collaboration with the RNIB and other low vision specialists. The 15W daylight energy saving bulb reduces glare and improves contrast allowing you to read and write for longer in optimal comfort. The Flexi-Vision Floor lamp is also one of the safest lamps on the market with clear on/off switch location, anti-trip cable holders and low heat shade.

---

LED 6,000K daylight

---

2,560 Lux at 12"

---

LED bulb included

---



LIGHT QUALITY



ERGONOMICS



DESIGN

[daylightcompany.com](http://daylightcompany.com)

# Flexi-Vision™

U31067

## RING LAMP

### FEATURES

- Unique floor lamp, designed in cooperation with the RNIB
- Low heat shade fitted with 15W daylight™ LED bulb (100W equiv.)
- Daylight™ technology reduces glare and improves contrast
- Read and write for longer in optimal comfort
- Height adjustable for reading on a sofa or at a table
- Flexible arm for easy positioning and extra reach
- Multi-swivel head to direct the light where you need it
- Anti-trip cable holders and clear on/off switch location
- Large wing nut for easy height adjustment
- Well-balanced base for enhanced stability

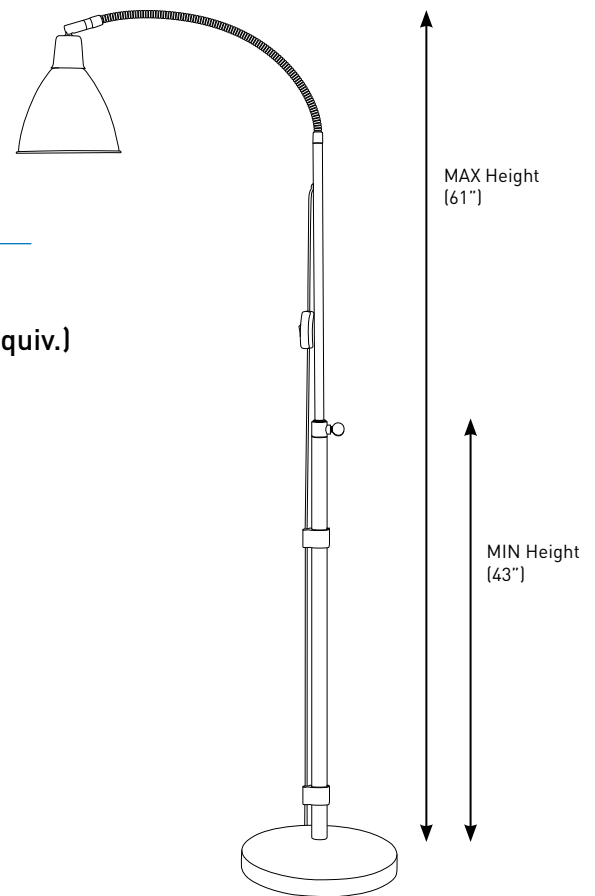

### SPECIFICATIONS

#### Product information

Weight	13.2lb
Color	Brushed Steel
Cable length	78.7"

#### Light output

Light source	LED
Lux Levels at 12"	2,650
Lumens	1,600
Color temperature	6,000K
CRI	80+
Energy consumption	15W

#### Packaging information

Height	29.7"
Width	14.2"
Depth	6.3"
Packed weight	16.6lb
Products per master carton	1
Barcode Number	8 09802 31067 2